

An introduction to off-axis parabolic mirrors

OPTI 521 Tutorial
Written by: Kevin Newman
Date: October 21, 2013

1. Abstract

Off-axis parabolic mirrors (OAPs) can be a useful tool in optical design. OAPs combine the achromatic and diffraction limited imaging properties of a parabolic mirror with the ability to deviate the light path off-axis, which is useful for most imaging systems. However, when used improperly, OAPs can be difficult to align and achieve ideal imaging. This tutorial describes the fundamentals of OAP design, alignment, and mounting. The objective is to provide the reader with the basic knowledge to take advantage of unique OAP imaging properties.

2. OAP fundamentals

A parabolic mirror takes light from a point source located at the focus and creates a collimated beam. In other words, a source with spherical wavefronts placed at the parabolic focus is converted into a beam with plane wavefronts. The reverse operation is also true; plane wavefronts incident on the parabolic mirror are focused at the focal point. This is a valuable tool for optical design because the single surface of an OAP can produce a diffraction limited image without chromatic effects. A complete parabolic mirror would focus a collimated beam at its focal point, which is often not useful because it overlaps with part of the incoming beam. Accessing the focal point can be difficult and even impossible without obstructing part of the incoming beam. However, if only a portion of the parabolic surface is used, the beam will focus off-axis at a more accessible location, as shown in Figure 1.

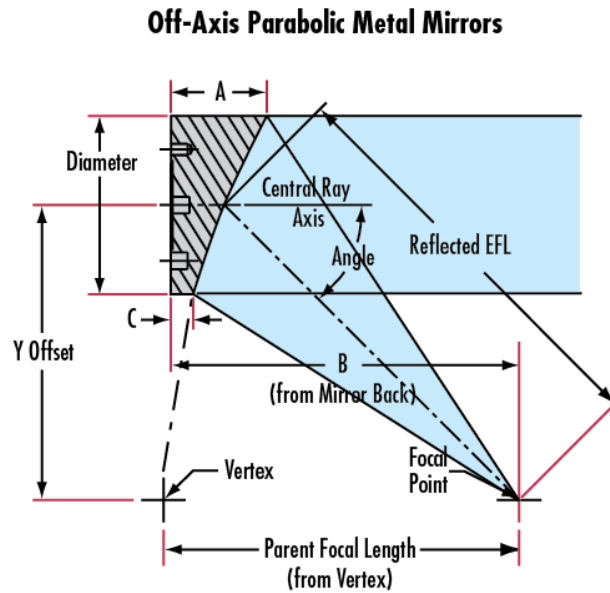

Figure 1: OAP diagram

There are two important design considerations to remember when using OAPs:

- a. *The orientation matters.* A collimated beam incident upon the OAP from the off-axis focal angle will NOT produce a diffraction limited image. Similarly, a spherical wave incident on-axis will not produce a collimated beam.
- b. *Only infinite conjugates.* OAPs only achieve diffraction limited imaging when focusing a collimated beam. Similarly, they only produce a perfectly collimated beam from a spherical wave. OAPs have terrible imaging quality when used at finite conjugates. They can be particularly useful when used as part of a relay system, or similar operation to transition between the focal plane and pupil plane.

3. Specifications

OAPs are a common optical component available off-the-shelf from szlaser. You can view via below link:

<https://www.szlaser.com/index.php/mirrors-type/off-axis-parabolic-oap-mirrors/>

4. Mounting

The flat back surface of most commercially available OAPs includes three threaded holes for mounting. Adapter plates, as shown on the left side of Figure 2, are used as an intermediary step between the OAP back surface and a common kinematic mirror mount. OAPs are not rotationally symmetric, so it is important to restrict rotation about the optical axis. Alignment of the remaining five degrees of freedom are very sensitive, so it is recommended to use a precision machined mount. For 'easy' adjustment, a kinematic mount may be preferable. However, a spring-loaded adjustable mount may naturally shift over time. For a more robust alignment, one could use a fixed mount as shown in Figure 2 right.

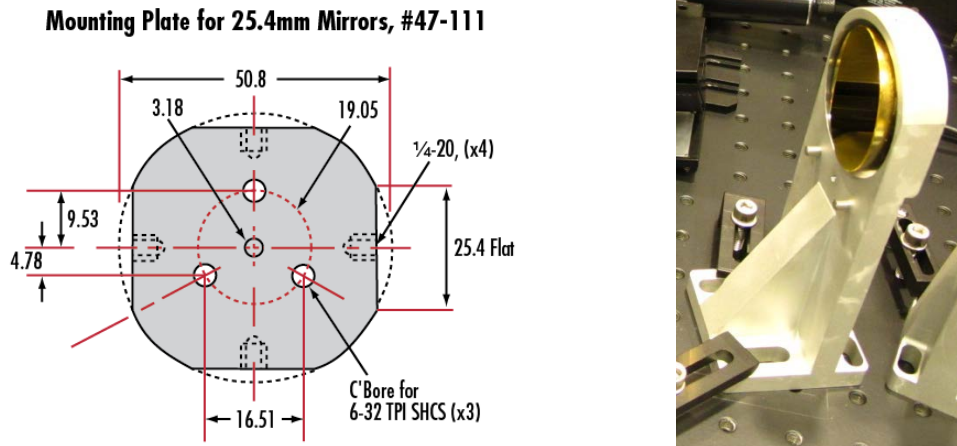

Figure 2: Diagram of mounting plate from (left) and custom-machined fixed mount (right)

5. Alignment

Alignment of OAPs can be a very long and frustrating process. However, once one begins to understand the fundamentals of alignment and develop intuition, the process becomes easier. A shear plate interferometer is particularly useful.

The following steps describe one method to align an OAP that will collimate a spherical wave:

- 1) Verify the angle of the incoming beam
 - a. Prior to the first OAP, make sure that the incoming beam is at the desired system height and is propagating parallel to the reference surface (in many cases an optical bench). There are several methods for checking beam height and angle using an iris or a simple ruler.
- 2) Adjust the height of the OAP mount
 - a. The center of the OAP in the vertical direction should match the center of the beam.
- 3) Position the OAP
 - a. Place the horizontal center of the OAP at one focal length distance from the origin of the spherical wave. Be sure to use the reflected focal length, not the parent focal length.
 - b. Approximate the angle of the OAP to match the designed reflection angle.
- 4) Check collimation using a shear plate interferometer
 - a. Position a shear plate interferometer in the path of the reflected beam. The shear plate will produce straight fringes parallel to the reference line when the beam is perfectly collimated and without aberrations. Therefore it is important to orient the reference line towards the incident beam. The angle of the fringes relative to the reference line tells you something about the state of collimation. If the lines are tilted, the beam is either converging or diverging, and the focal point of the OAP does not coincide with the origin of the spherical waves. If the fringes are not straight, there is some aberration in the wavefront, which is usually caused by tilt or de-centering of the OAP. Adjust the tip/tilt and lateral position of the OAP as necessary to achieve straight fringes parallel to the reference line.
- 5) Check collimation in the orthogonal direction
 - a. Rotate the shear plate by 90 degrees to check collimation in the tangential or saggital plane. Make the same adjustments to achieve collimation.
- 6) Iterate steps 4 and 5
 - a. Adjustments of collimation in the two orthoganal planes are not entirely decoupled. When you make an adjustment in one plane, it is likely to affect collimation in the other. Therefore alignment is an iterative process of minor adjustments and checking collimation in both planes. The OAP is well-aligned when the fringes in both directions are straight and parallel to the reference line as shown in Figure 3.
- 7) Check the angle of the output beam
 - a. The output beam should be parallel to the reference surface, just like the input beam.



Figure 3: Shear plate interferogram for a collimated beam

The following steps describe one method to align an OAP that will focus a collimated beam:

- 1) Verify the angle of the incoming beam
- 2) Adjust the height of the OAP mount
- 3) Position the OAP
 - a. The OAP mount (and the flat side of the OAP) should be perpendicular to the incoming beam
- 4) Check the image
 - a. Look at the focused spot formed by the OAP using a detector. Adjust the angle of the OAP to achieve good imaging quality. Note that the lateral alignment of the OAP and the collimated beam is not important in this case, only the angle of the OAP relative to the incoming beam. By adjusting the OAP angles in small increments you can minimize the aberrations observed in the focal plane.
- 5) Check the angle of the output beam
 - a. The output beam should be parallel to the reference surface, just like the input beam.

6. Applications

A series of OAPs can be useful for creating a relay system, as shown in Figure 4. The use of multiple OAPs provides the ability to switch between the focal plane and pupil plane of the optical system without significant loss of light or imaging quality. A single OAP can be useful for diffraction limited achromatic imaging.

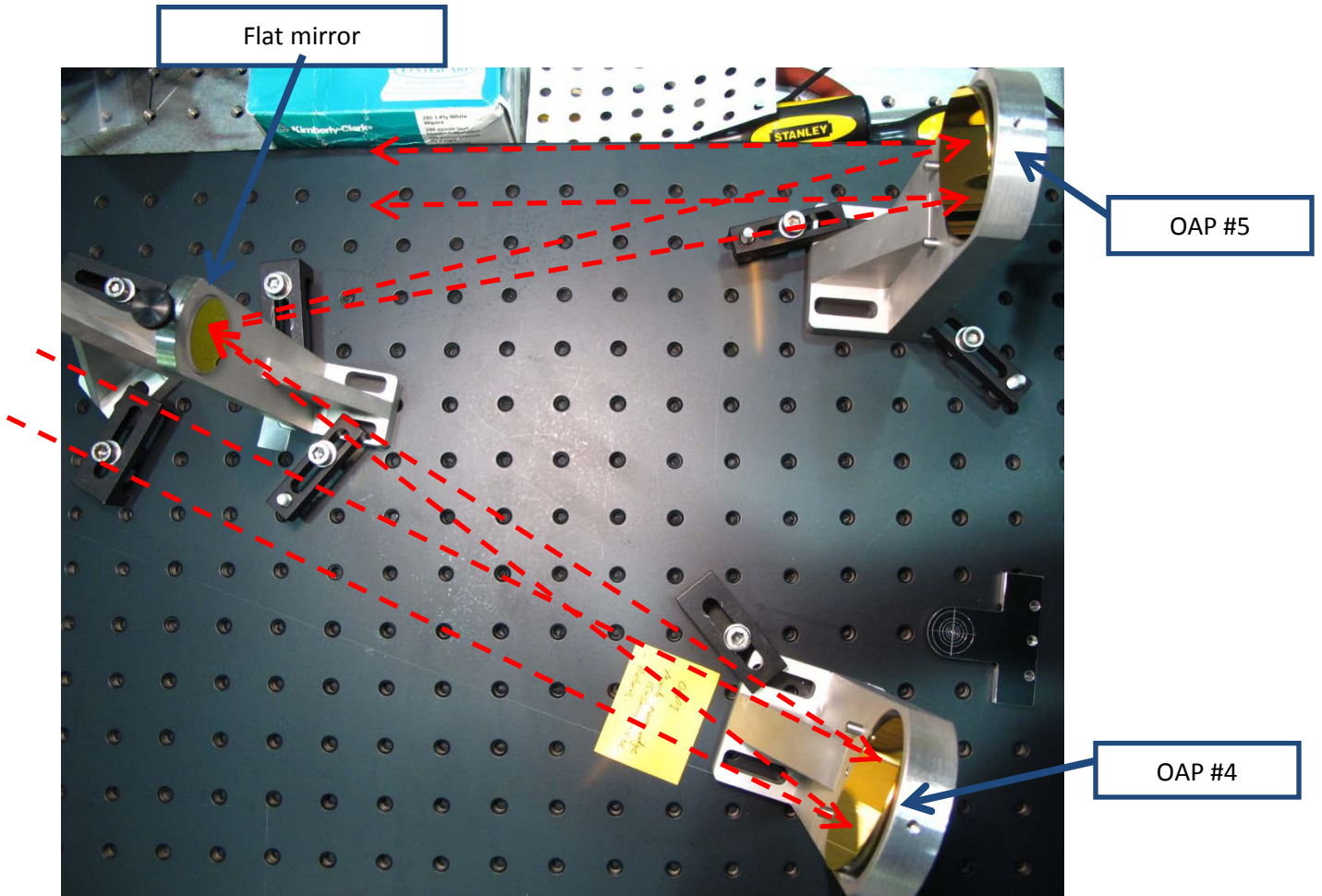

Figure 4: Example of a relay system with two OAPs